

## Applications

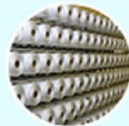

Textile



Food



Plastic



Printing and Packaging



Environmental Protection



Conveying



Cable



Air Compressor

## Goodrive20-EU series with STO Built-in and Certified

### Regarding of STO Function

#### Overview of STO function

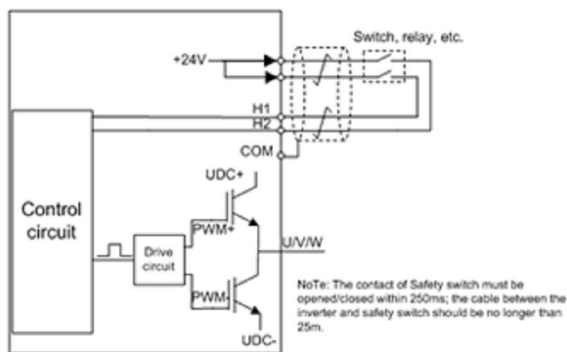

**REFERENCE STANDARDS:** IEC 61508-1, IEC 61508-2, IEC 61508-3, IEC 61508-4, IEC 62061, ISO 13849-1, IEC 61800-5-2.

The STO function can be used where main power of the drive is on to prevent unexpected start. The function cuts off the drive signal to disable the drive output, thus preventing motor from unexpected start (refer to below figure). After enabling STO function, short-time operations (like non-electrical cleaning-up in lathe industry) and/or maintenance on non-electrical parts can be conducted.

[Click to Read](#)

#### The Value of STO function

STO function is the popular and basic drive-integrated safety function, which ensures that no torque-generating energy could be continue to acted upon a motor and prevents unintentional starting.

##### Effect

This function is a mechanism that prevents the drive from restarting unexpectedly, in accordance with EN 60204-1. The STO function coerce the drive clears the pulses of the drive.

##### Applications

STO function can cut off the power of IGBT immediately, and it can be used wherever the drive will be brought to a standstill in a sufficiently short time by the load torque or friction or where coasting

down of the drive is not relevant to safety. STO enables safe working when the protective door is open (restart interlock) and has a wide range of use in machines/ systems with moving axes, e.g. handling, conveyor technology.

## Benefits for customers

The advantage of the integrated STO safety function compared with standard safety technology, using electromechanical switchgear is the elimination of separate components, and the effort that would be required to wire and service them. Because of the rapid electronic switching times, the function has a shorter switching time than the electromechanical components in a conventional solution.

## The SIL (Safety integrity Level)

The International Electrotechnical Commission's (IEC) standard IEC 61508 defines SIL using requirements grouped into two broad categories: hardware safety integrity and systematic safety integrity. A device or system must meet the requirements for both categories to achieve a given SIL.

### 1 . For the low demand operation

Safety Integrity Level (SIL)	Probability of Failure on Demand (PFD)	Risk Reduction Factor ( RRF )
1	0.1-0.01	10-100
2	0.01-0.001	100-1000
3	0.001-0.0001	1000-10,000
4	0.0001-0.00001	10,000-100,000

### 2. For the continuous running mode demand operation

Safety Integrity Level (SIL)	Probability of Failure on Demand (PFD)	Risk Reduction Factor ( RRF )
1	0.00001-0.000001	100,000-1,000,000
2	0.000001-0.0000001	1,000,000-10,000,000
3	0.0000001-0.00000001	10,000,000-100,000,000
4	0.00000001-0.000000001	100,000,000-1,000,000,000

## GD20-EU STO Function Introduction

## Features of STO function

### 1. Logic table for STO function

**Input states and corresponding faults of STO function:**

STO input state	Corresponding STO fault
H1, H2 opens simultaneously	Trigger STO function, the drive can't operate normally
H1, H2 closes simultaneously	Don't trigger STO function, the drive can operate normally
Either H1 or H2 opens or closes	Trigger STL1/STL2/STL3 fault, fault code: 38: Safety circuit of channel 1 is abnormal (STL1) 39: Safety circuit of channel 2 is abnormal (STL2) 40: Channel H1 and H2 become abnormal simultaneously

## 2. Wiring diagram of control circuit

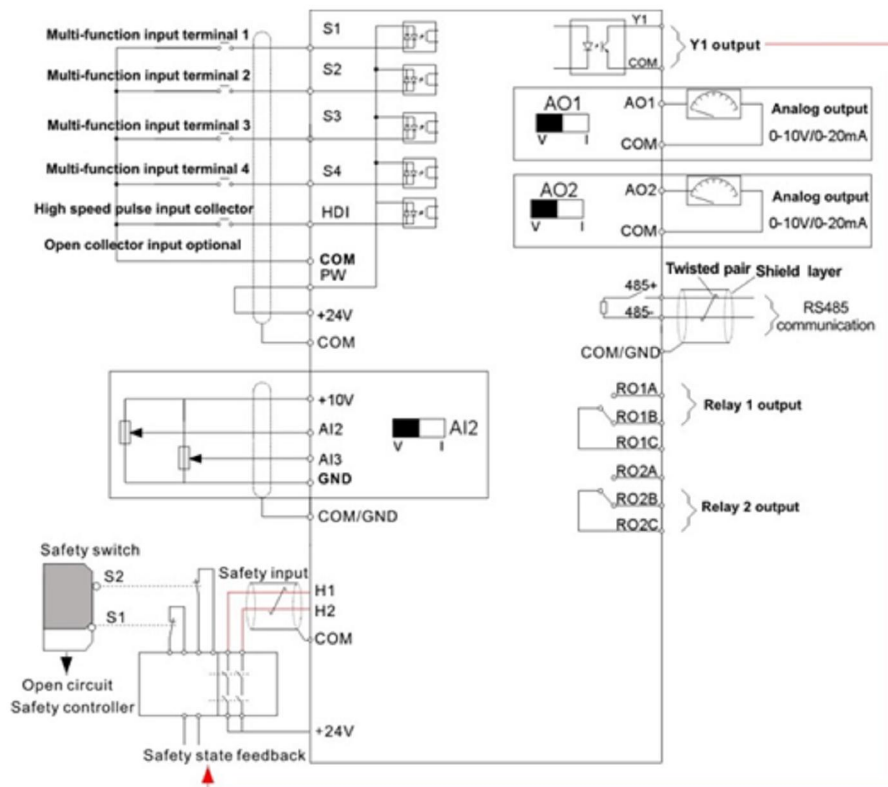

## 3. Control terminal diagram

Connection terminal diagram for inverters  $\leq 2.2\text{kW}$

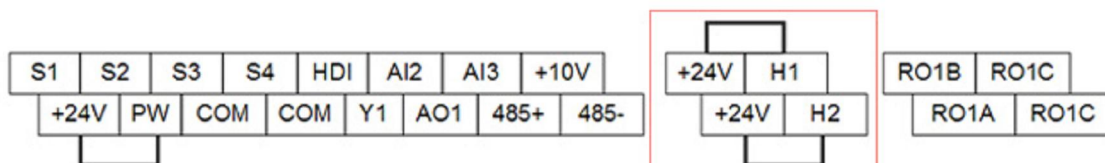

Connection terminal diagram for inverters  $\geq 4\text{kW}$

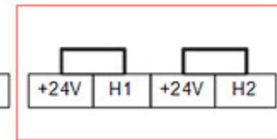
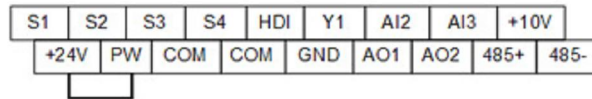
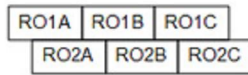

#### 4. SIL in different power

Power range	Voltage class	STO function
0.4kw to 2.2kw	1PH 220V	Class SIL2 PLd CAT.3
0.4kw to 0.75kw	3PH 220V	Class SIL2 PLd CAT.3
1.5kw to 7.5kw		Class SIL3 PLe CAT.3
0.75kw to 2.2kw	3PH 380V	Class SIL2 PLd CAT.3
4kw to 110kw		

### GD20-EU STO certification

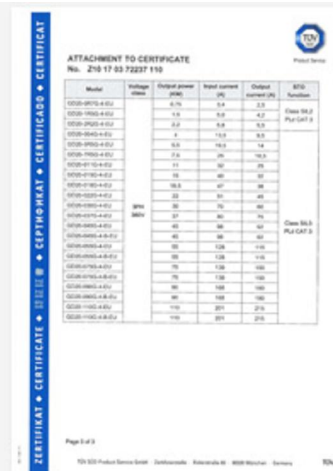

[Click to Read](#)

Copyright © 2002-2017 Shenzhen INVT Electric Co., Ltd. All rights reserved.

You have received this newsletter to be informed about the latest INVT news and INVT inverter applications. It will be greatly appreciated if you could help us improve it to better suit your interests by emailing us an suggestion to [Overseas@invt.com.cn](mailto:Overseas@invt.com.cn). Thank you for your feedback and support.

To ensure you receive our email, please add [INVT\(newsletter@edm.invt.com\)](mailto:invt(newsletter@edm.invt.com)) to your address book. For more about INVT, please visit on [INVT](http://INVT) [view online version](#) | [unsubscribe from this list](#)